



# DB DECONNECTORS

INSDB 032709 D



Meltric Corporation  
4640 Ironwood Drive  
Franklin, WI 53132  
(800)433-7642  
www.meltric.com

## GENERAL

DB Deconnector™ Series products are designed to provide the safety and functionality of a switch with the convenience of a plug & receptacle. They can safely be used to make and break electrical connections, even in overload situations and are an approved 'line of sight' disconnect switch. Please follow the instructions below to ensure the proper installation and use of the product.

## RATINGS

DB Deconnectors are UL & CSA listed as switch rated plugs and receptacles in accordance with UL Subject 2682, UL 1682 and CSA 22.2 No. 182.1. DB Deconnectors are listed as 'Branch Circuit Disconnect Switches' and are also horsepower rated and listed as 'Motor Circuit Disconnect Switches'. The amperage, voltage, horsepower, switch and environmental ratings are indicated on the product labels.

All Deconnectors are rated to make and withstand short circuit currents of 100 kA or more. These ratings are indicated in Table 1 along with the fusing upon which they are based.

Device	Rating Fuse	Type*
DB30 - 30A	100kA @ 600 VAC	RK1 125A
DB60 - 60A	100kA @ 600 VAC	RK1 250A
DB100 - 100A	100kA @ 600 VAC	RK1 250A**

\* Rating applies with fusing up to this amperage. Ratings are based on tests performed with Ferraz Shawmut non-time delay current limiting fuses.

\*\* The fusing used limits the 100kA rating to 60hp @ 600V, 40hp @ 480V, 20hp @ 240V & 208V. The device is rated for 10kA for all hp ratings where the 100kA rating does not apply.

## INSTALLATION

Deconnectors should be installed by qualified electricians in accordance with all applicable local and national electrical codes. Before starting, verify that the power is off, that the product ratings are appropriate for the application, and that the conductors meet

code requirements and are within the capacities of the terminals noted in Table 2.

Device	Main Contacts		Aux. Contacts <sup>2</sup>
	Minimum	Maximum	Maximum
DB30 - 30A	14	8	14
DB60 - 60A	8	3	14
DB100 - 100A	1/0	2/0	14

<sup>1</sup> Capacity is based on THHN wire sizes

<sup>2</sup> Auxiliary contacts are optional and may not be on all products.

## General Notes & Precautions

- Self-tapping screws are provided for use with some polymeric accessories. High torque may be required to drive them in. Once they are seated, care should be taken in order to avoid over-tightening them against the plastic material.
- Various handles and cord grip options may be used. These instructions are based on handles provided with integral multi-layer bushing cord grips.
- Wire strip lengths are indicated in Table 3. Strip lengths for cable sheathing will depend on the specific application. When used with handles, the cable sheathing should extend into the handle to ensure secure cord gripping.



Device	Phase & Neutral		Ground	
	Inches	mm	Inches	mm
DB30 - 30A	3/4	19	1/2	12
DB60 - 60A	13/16	20	5/8	15
DB100 - 100A	1 3/8	35	1 3/16	30

- Wiring terminals are spring assisted to prevent loosening due to stand settlement, vibration and thermal cycling. They should not be over-tightened. Appropriate tools and tightening torques are indicated in Table 4.

▲ Do not back terminal screws completely out

Device	Torque		Required Screwdriver Flathead type
	in-lbs	N-m	
DB30 - 30A	15	1.7	3 mm or 1/8" precision tip
DB60 - 60A	23	2.7	5 mm or 3/16" precision tip
DB100 - 100A	39	4.5	6 mm or 1/4" precision tip

## Assembly for Mounted Receptacles (or Inlets)

In applications where DB receptacles (or inlets) are mounted to wall boxes, panels or other equipment, optimal operation is achieved when the device is installed with the viewing window at the top.

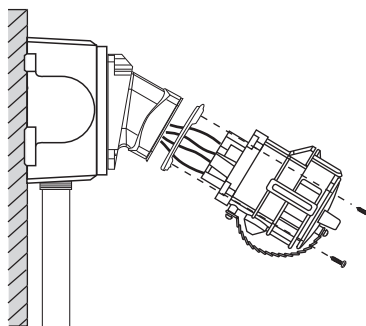

Insert the cable or wires through the wall box and cut to allow adequate length, strip the cable sheath as desired, strip the individual wires to the lengths indicated in Table 3, and twist the strands of each conductor together. Back out the terminal screws on the receptacle (or inlet) far enough (but NOT completely) to allow the conductors to pass, insert the conductors fully into their respective terminals and hand tighten the terminal screws to the torque indicated in Table 4.

Assemble the receptacle (or inlet) and the color-coded gasket to the box using the appropriate hardware. Assemble the mating plug (or receptacle) to the cord end as indicated in the assembly instructions above for in-line connections.

## Assembly for Plugs (or Connectors)

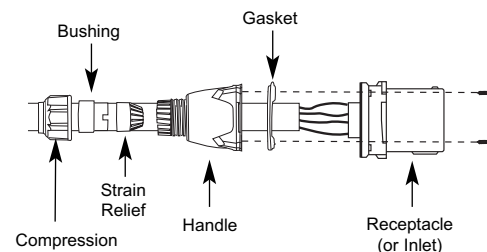

When assembling male inlets (or female receptacles) to handles with integral multi-layer bushing cord grips, adjust the bushing diameter to fit the cable by removing inner sections of it as required. Insert the bushing into the strain relief, then insert the assembly into the handle and loosely install the compression nut. Insert the cable through the handle, the thin black drawplate gasket and finger drawplate (if applicable) and the color coded gasket. Strip the cable sheath to provide a workable wire length, being mindful that the sheath must extend into the handle to achieve a secure cord grip. Then strip the individual wires to the lengths indicated in Table 3 and twist the strands of each conductor together.

Back out the terminal screws on the receptacle (or inlet) far enough (but NOT completely) to allow the conductors to pass, insert the conductors fully into their respective terminals and tighten the terminal screws with the appropriate tool to the torque indicated in Table 4.

Verify that the cable sheath extends beyond the strain relief and into the handle. Assemble the receptacle (or inlet), the color coded gasket, the finger drawplate, and the thin black drawplate gasket to the handle with the four self-tapping screws provided. Adjust the cable location so that it will not be under tension inside the handle and tighten the compression nut to secure the cable.

## Hole Pattern for Custom Mounting

In applications where custom mounting to a panel or box is being performed, the clearance and mounting holes should be drilled as indicated in the following diagram and Table 5.

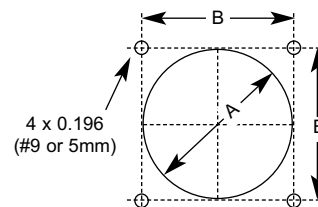

Table 5 - Custom Mounting Dimensions				
Model	'A'		'B'	
	Inches	mm	Inches	mm
DB30	2.17	55	2.17	55
DB60	2.68	68	2.59	66
DB100	3.35	85	3.2	81

In order to maintain the IP protection provided by DB models in custom installations, watertight seals should be used under the heads of the four mounting bolts and they must be retained by a lock washer and nut on the inside of the box or panel. Alternatively, four blind holes may be drilled and threaded to accommodate the mounting screws, provided that the hole depth is sufficient to achieve adequate gasket compression.

## OPERATION

To ensure safe and reliable operation Meltric plugs and receptacles must be used in accordance with their assigned ratings. They can only be used in conjunction with mating receptacles or plugs manufactured by Meltric or another licensed producer of products bearing the **Marechal**™ technology trademark.

Meltric plugs & receptacles are designed with different keying arrangements, so that only plugs and receptacles with compatible contact configurations and electrical ratings will mate with each other.

## Connection

First remove the lid on the receptacle by turning the locking ring fully counterclockwise. The lid can then be removed. For convenience it remains attached to the receptacle by a wire.

To insert the plug into a receptacle, the arrow on the plug casing is aligned with the left end of the viewing window on the receptacle, Figure 1. Push the plug partially into the receptacle until it hits a stop then rotate slightly clockwise. The plug is now in the rest position with circuit open.

Push the plug straight into the receptacle until it is held in place by the locking ring Figure 2. The electrical connection is now made as indicated by the red color in the viewing window. IP67 watertightness is achieved by fully rotating the locking ring in the clockwise direction until the protruding lockout tab completely clears the window shroud.

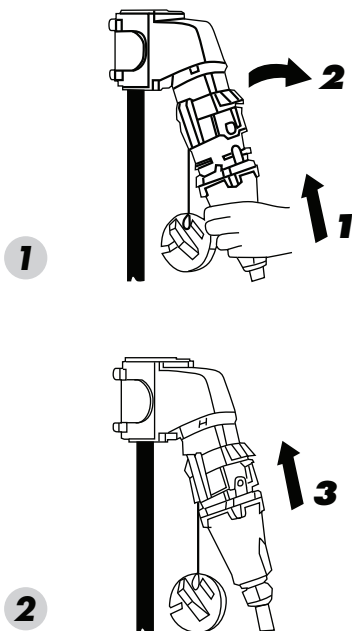

## Disconnection

To break the connection, turn the locking ring fully counterclockwise. This will break the circuit and eject the plug straight out to the rest or off position. The plug contacts are deenergized at this point. To remove the plug, rotate it counterclockwise (about 10°) until it can be withdrawn from the receptacle, Figure 3. Insert the lid and rotate the locking ring fully clockwise to provide IP67 protection to the receptacle, Figure 4.

- ▲ Plug has to be brought back to its rest position before another engagement is possible.

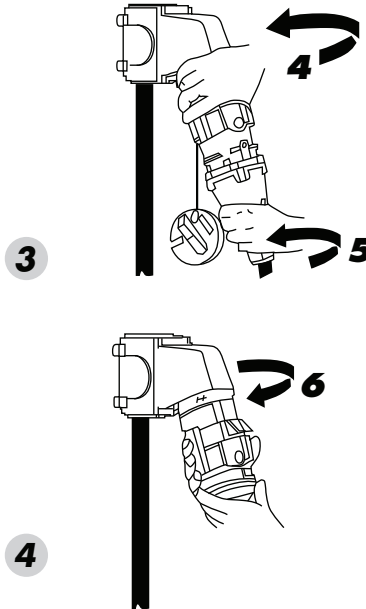

## Achieving Rated Watertightness

Rated ingress protection is achieved when the plug and receptacle are mated and the locking ring is fully rotated in the clockwise direction. It can also be achieved by the receptacle when the lid is inserted and the locking ring is fully rotated in the clockwise direction.

- ▲ Proper steps must be taken to maintain water tightness at NPT fittings on the plug handles or at the junction box. Use of a sealer tape is recommended.

## Lockout Provisions

All DB plugs and receptacles are provided with lockout provisions.

### Plug Lockout

To prevent the DB plug from being inserted into any DB receptacle place a padlock or a safety lockout through the hole provided.

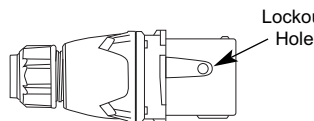

### Receptacle Lockout

Insert the lid and fully rotate the locking ring clockwise. A padlock or safety lockout can then be inserted in the hole on the locking ring.

### Locking Plug and Receptacle in Closed Position

To lock the plug and receptacle in the closed position a knock-out hole located on the receptacle locking

ring must first be opened with the help of a 1/4" punch. When the plug and receptacle are engaged and the locking ring is fully rotated then the lockout hole will have cleared the window shroud and a padlock or safety lockout can be inserted.

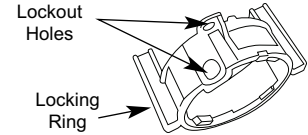

### Locking Plug and Receptacle in the Open or Parked Position

When the plug is in the rest or off position the lockout holes on the locking ring and plug can be aligned. Insert a safety lockout device through both holes to lock the unit in the parked position.

## MAINTENANCE

Meltric products require little on-going maintenance. However, it is a good practice to periodically perform the following general inspections:

- Check the mounting screws for tightness.
- Verify that the weight of the cable is supported by the strain relief mechanism and not by the terminal connections.
- Check the IP gaskets for wear and resiliency. Replace as required.
- Verify the electrical continuity of the ground circuit.
- Check the contact surfaces for cleanliness and pitting.

Use a clean cloth to rub off deposits of dust or similar foreign materials on the contacts and the plug interiors. Sprays should not be used, as they tend to collect dirt. If any significant pitting of the contacts or other serious damage is observed, the device should be replaced.

## MANUFACTURER'S RESPONSIBILITY

Meltric's responsibility is strictly limited to the repair or replacement of any product that does not conform to the warranty specified in the purchase contract. Meltric shall not be liable for any penalties or consequential damages associated with the loss of production, work, profit or any financial loss incurred by the customer.

Meltric Corporation shall not be held liable when its products are used in conjunction with products not bearing the **Marechal**™ technology trademark. The use of Meltric products in conjunction with mating devices that are not marked with the **Marechal**™ technology trademark shall void all warranties on the product.

**Meltric Corporation** is an ISO 9001 certified company. Its products are designed, manufactured and rated in accordance with applicable UL, CSA and IEC standards. Meltric is also a member of BECMA, the international Butt-contact Electrical Connectors Manufacturers' Association. Like all members, Meltric additionally designs and manufactures its products in accordance with BECMA standards established to ensure intermatability with similarly rated products manufactured by other members.



www.becma.ch