

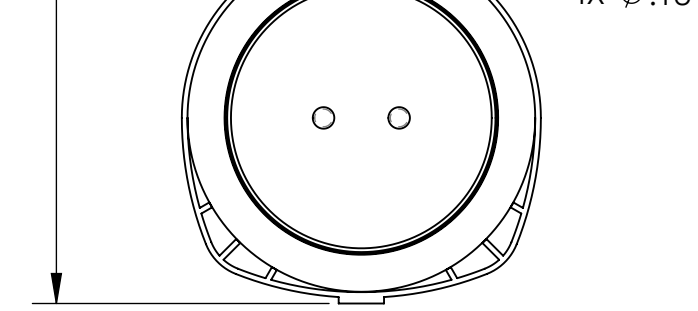

This drawing is the property of MELTRIC Corporation, Franklin (Milwaukee) Wisconsin, USA. Any unauthorized copying of this drawing by any means, ENG/RD/06 REV: 20 ISSUED DATE: 1/15/11 or disclosure of its contents to any person not authorized by MELTRIC Corporation or its agents to receive it, is strictly prohibited.

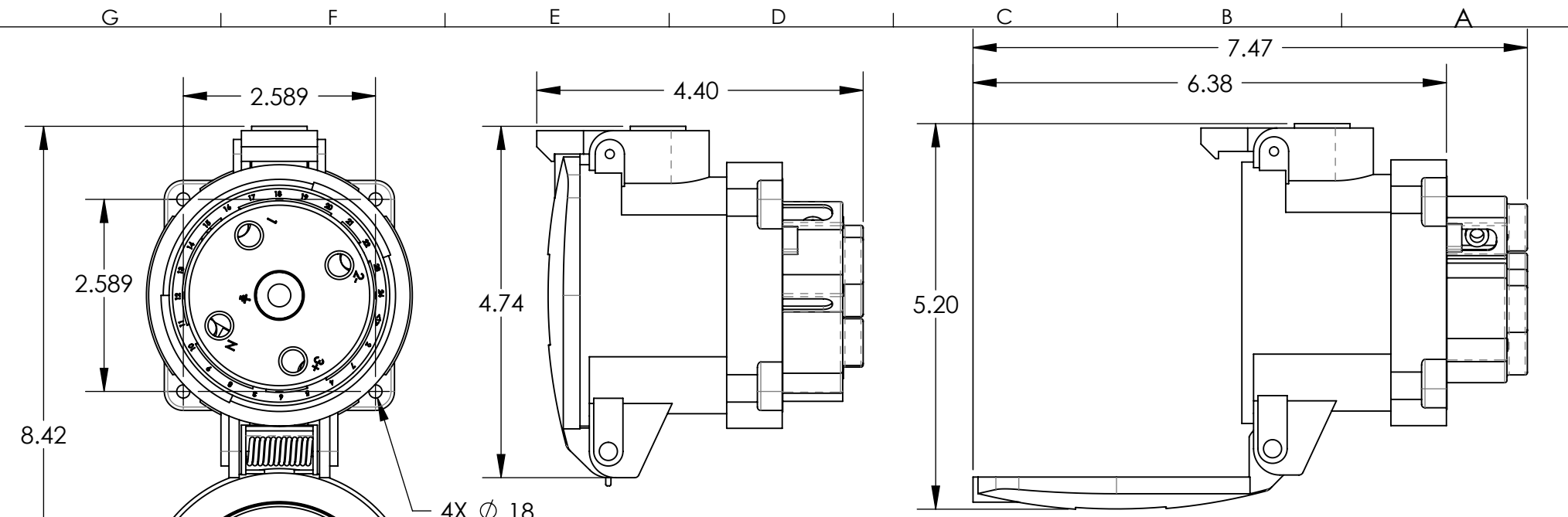

ENTRY HOLE PATTERN

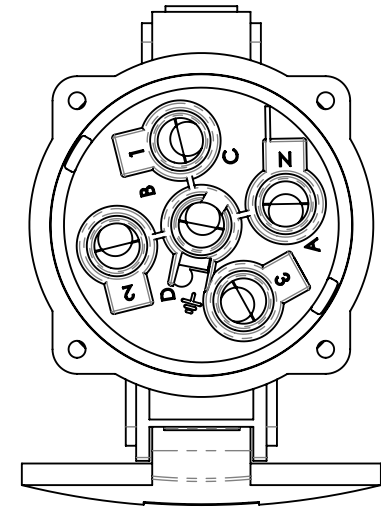

TOLERANCES UNLESS OTHERWISE SPECIFIED	
MACHINED SURFACES $\sqrt[125]{\text{MAX}}$	ENGLISH 0.X \pm0.05 0.XX \pm0.01 0.XXX \pm0.005
GROUND SURFACES $\sqrt[32]{\text{MAX}}$	
ANGLE TOLERANCE $\pm 1^\circ$	
REMOVE BURRS & SHARP EDGES TO .015 MAX.	
 DIMENSIONS SHOWN IN OVALS ARE INSPECTION DIMENSIONS.	

		MELTRIC CORPORATION	
DRAWN	APPROVED	DRAWING TITLE:	
DATE:	SCALE	DS100C METAL RECEPTACLE	
SHEET:	PART NUMBER	MATERIAL:	
1 OF 1	37-64xxx-C-Kxx	METAL CASING	
			REVISION