



**DN7c/DN9c/DN20c  
MULTIPIN**

INSDN 072711 E



Meltric Corporation  
4640 Ironwood Drive  
Franklin, WI 53132  
(800)433-7642 • www.meltric.com

**GENERAL**

Meltric's DN7c, DN9c and DN20c series industrial, multipin plugs and receptacles are designed to ensure safety and provide reliable electrical connections. Please follow the instructions below to ensure proper installation and safe use of the product.

**RATINGS**

These products are manufactured and rated in compliance with applicable standards. The product ratings are indicated on the device's labels.

**INSTALLATION**

These products should be installed by qualified personnel in accordance with all applicable local, state and national electrical codes. Before starting, verify that the power is turned off; the product ratings are appropriate for the application; and the conductor sizes are within the capacities of the terminals noted on Table 1.

Device	Contacts	
	Min	Max
DN7c (50A)	10	6
DN7c (90A)	8	2
DN7c (150A)	6	3/0
DN9c	16	10
DN20c	16	10

\*Capacity is based on THHN wire sizes.

**General Notes & Precautions**

- Self-tapping screws are provided for use with some polymeric accessories. Once they are seated, care should be taken in order to avoid over-tightening them against the plastic material.
- Various handles, cord grips or strain relief options may be used. These instructions are based on handles provided with integral, multi-layer, bushing cord grips.
- Wire strip lengths are indicated in Table 2. Strip lengths for cable sheathing will depend on the specific application.



Device/Contacts	Receptacle		Plug/Inlet	
	Inches	mm	Inches	mm
DN7c (50A) Contact	3/4	20	3/4	20
DN7c (90A) Contact	1	25	1	25
DN7c (150A) Contact	1 3/16	30	1 3/16	30
DN9c Contacts	1/2	13	1/2	13
DN20c Contacts	1/2	13	1/2	13

- Wiring terminals are spring-assisted to prevent loosening due to wire strand settlement, vibration and thermal cycling. They should not be over-tightened. Appropriate tools and tightening torques are indicated in Table 3.

Device/Contact	Torque		Required Screwdriver or Allen Wrench
	in-lbs	N-m	
DN7c (50A) Contact	13.3	1.5	5/64" hex head 2mm hex head
DN7c (90A) Contact	30.0	3.5	1/4" precision tip
DN7c (150A) Contact	80.0	9.0	4 mm hex head
DN9c Contact	4.50	0.5	5/64" hex head 2mm hex head
DN20c Contact	4.50	0.5	5/64" hex head 2mm hex head

The DN9c and DN20c plugs and receptacles's contacts are labeled with F or S numbers respectively. The F-number on the inlet has a corresponding S-number on the receptacle. See table 4 for details.

Plug/Inlet Contact Nos.	Corresponding mating pin	Receptacle Contact Nos.
F1 (Ground)	→	S1 (Ground)
F2	→	S2
F3	→	S3
F4	→	S4
F5	→	S5
ETC	→	ETC
F20	→	S20

**Assembly for In-line Connections**

When the DN9 and 50A DN7c products are used as in-line connectors, finger drawplates should be installed on both the receptacle and plug in order to provide the user with the leverage to connect the device (finger drawplates are not available on DN20c or 90A and 150A DN7c devices).

**NOTE:** The longer screws provided with the finger drawplates must be used when assembling devices with finger drawplates because the shorter screws provided with the handle are not long enough to properly secure both the handle and drawplates to the inlet or receptacle and achieve a watertight connection.

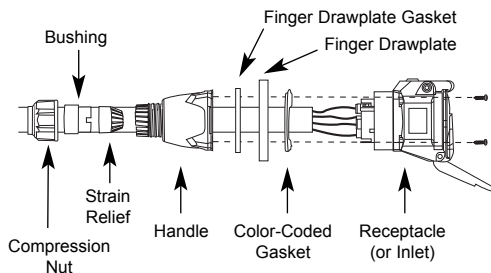

Adjust the bushing diameter to fit the cable by removing the inner sections as required. Insert the bushing into the strain relief, then insert the assembly into the handle and loosely install the compression nut. Insert the cable through the handle, the thin black (neoprene) drawplate gasket, the finger drawplate

(if applicable) and the color coded gasket. Strip the cable sheath to provide a workable wire length, being mindful that the sheath must extend into the handle to achieve a secure cord grip. Then strip the individual wires to the lengths indicated in Table 2 and twist the strands of each conductor together.

Back out the terminal screws on the receptacle (or inlet) far enough (but not completely) to allow the conductors to pass. Insert the conductors fully into their respective terminals and tighten the terminal screws with the appropriate tool to the torque indicated in Table 3.

Verify that the cable sheath extends beyond the strain relief and into the handle. Assemble the receptacle (or inlet), the color coded gasket, followed by the finger drawplate, and the thin black (neoprene) drawplate gasket (if applicable) to the handle and tighten the compression nut to secure the cable.

**Assembly for Mounted Receptacles (or Inlets)**

In applications where the receptacles (or inlets) are mounted to wall boxes, panels or other equipment, optimal operation is achieved when the devices are installed with the latch at the top.

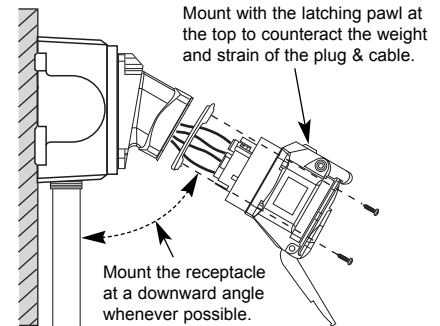

Insert the cable or wires through the wall box and cut to allow adequate length. Strip the cable sheath as desired, then strip the individual wires to the lengths indicated in Table 2 and twist the strands of each conductor together. Back out the terminal screws on the receptacle (or inlet) far enough (but not completely) to allow the conductors to pass. Insert the conductors fully into their respective terminals and hand tighten the terminal screws to the torque indicated in Table 3.

Assemble the receptacle (or inlet) and the color coded gasket to the box with the appropriate hardware. Assemble the mating plug (or receptacle) to the cord end as indicated in the assembly instructions above for in-line connections, except there will be no finger drawplate or associated black gasket.

**Hole Pattern for Custom Mounting**

In applications where custom mounting to a panel or box is desired, the clearance and mounting holes should be drilled as indicated in the following diagram and Table 5.

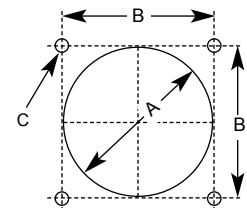

Table 5 - Custom Mounting Dimensions						
Model	'A'		'B'		C	
	Inches	mm	Inches	mm	Inches	mm
DN7c (50A)	3.25	83	2.59	66	.22	5.5
DN7c (90A)	4.00	102	3.20	81	.22	5.5
DN7c (150A)	4.50	114	3.86	98	.28	7.0
DN9c	2.70	69	2.18	55	.19	4.8
DN20c	4.00	102	3.20	81	.22	5.5

## OPERATION

To ensure safe and reliable operation, Meltric plugs and receptacles must be used in accordance with their assigned ratings. They can only be used in conjunction with mating receptacles or plugs manufactured by Meltric or another licensed producer of products bearing the **Ilarecha**™ technology trademark.

Meltric plugs & receptacles are designed with different keying arrangements so that only plugs and receptacles with compatible contact configurations and electrical ratings will mate with each other.

## Connection

To connect a plug and receptacle, first depress the pawl to open the lid on the receptacle and orient the plug as shown in figure 1. Push the plug partially into the receptacle until it hits a stop and then rotate the plug in the counter-clockwise direction about 30°. At this point, the circuit is still open. Push the plug straight into the receptacle 2 until it becomes securely latched in place. The electrical connection is now made. For in-line connections, the use of finger drawplates is recommended. When finger drawplates are used, squeeze the drawplates on both sides of the device together until the plug latches in place.

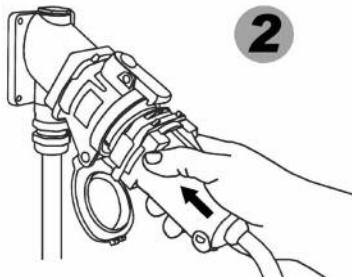
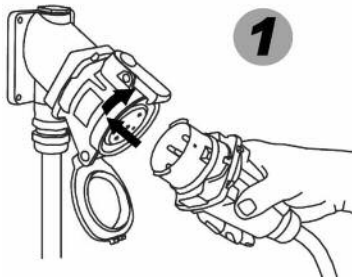

## Disconnection

To disconnect, simply depress the pawl 3. This will open the circuit and eject the plug straight out to the rest or off position. The plug contacts are de-energized at this point. To remove the plug, rotate it clockwise about 30° until it releases from the receptacle 4. Close and latch the lid on the receptacle.

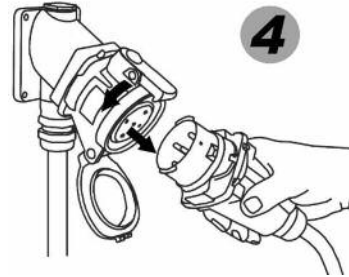
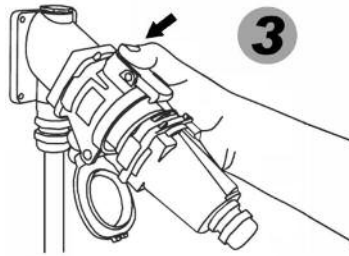

## ACHIEVING RATED WATERTIGHTNESS

Rated ingress protection applies to the device when the plug and receptacle are mated and latched together. It also applies to the receptacle when the lid is latched closed.

## LOCKOUT PROVISIONS

Some Meltric receptacles may be purchased with optional lockout provisions. To lockout the receptacle, close and latch the lid and then attach the locking device through the hole provided in the pawl or shroud. This will prevent the lid from being opened for the insertion of a plug.

**NOTE:** Attaching the receptacle locking device with the receptacle lid open will not prevent the insertion of a plug. Lockout is only accomplished when the lid is locked closed.

## MAINTENANCE

Meltric products require little on-going maintenance. However, it is a good practice to periodically perform the following general inspections:

- Check the mounting screws for tightness.
- Verify that the weight of the cable is supported by the strain relief mechanism and not by the terminal connections.
- Check the IP gaskets for wear and resiliency. Replace as required.
- Verify the electrical continuity of the ground circuit.
- Check the pin contact surfaces for cleanliness and pitting.

Deposits of dust or similar foreign materials can be rubbed off the contacts with a clean cloth. Sprays should not be used, as they tend to collect dirt. If any significant pitting of the contacts or other serious damage is observed, the device should be replaced.

Receptacle contacts may be inspected by a qualified technician. This should only be done with the power turned off. The inlet contacts can be inspected by pressing on opposite ends of the numbered face. This will make it easier to check the contacts for pitting or damage.

## MANUFACTURER'S RESPONSIBILITY

Meltric's responsibility is strictly limited to the repair or replacement of any product that does not conform to the warranty specified in the purchase contract. Meltric shall not be liable for any penalties or consequential damages associated with the loss of production, work, profit or any financial loss incurred by the customer.

Meltric Corporation shall not be held liable when its products are used in conjunction with products not bearing the **Ilarecha**™ trademark. The use of Meltric products in conjunction with mating devices that are not marked with the **Ilarecha**™ trademark shall void all warranties on the product.

*Meltric Corporation is an ISO 9001 certified company. Its products are designed, manufactured and rated in accordance with applicable UL, CSA and IEC standards. Meltric is also a member of BECMA, the international Butt-contact Electrical Connectors Manufacturers' Association. Like all members, Meltric additionally designs and manufactures its products in accordance with BECMA standards established to ensure intermatibility with similarly rated products manufactured by other members.*



[www.becma.ch](http://www.becma.ch)