



**PN20/PN30
PN20HT/PN30HT
PN7c/PN12c**

INSPN D



Meltric Corporation
4640 Ironwood Drive
Franklin, WI 53132
(800)433-7642
www.meltric.com

GENERAL

PN Series plugs and receptacles are designed to offer superior safety, durability and consistent, electrical contact performance. Please follow the instructions below to ensure the proper installation, operation and maintenance of this product.

RATINGS

Meltric's PN Series Standard Duty plugs & receptacles are listed in accordance with UL 1682, CSA 22.2 No. 182.1 and IEC 60309-1. The amperage, voltage and environmental ratings are indicated in Table 1.

	PN12	PN7	PN20	PN30
Current Interrupting	5A	15A	20A	20A
Non-Current Interrupting	7A	20A	30A	30A
Voltage	600VAC	600VAC	600VAC	600VAC
Frequency	50-400 Hz	50-400 Hz	50-400 Hz	50-400 Hz
Environmental	IP66+67	IP66+67	IP66/IP67 IP54/IP55	IP66/IP67 IP54/IP55

*PN20HT and PN30HT are current interrupting up to 480V only, environmental rating is IP44.

INSTALLATION

PN Series plugs and receptacles should be installed by a qualified person in accordance with all applicable local and national electrical codes. Before starting, verify that the power has been disconnected, all product ratings are appropriate for the application and the conductors meet code requirements and are within the capacities of the terminals noted in Table 2. NPT Guidelines are detailed in Table 3.

Model	Wire Size	
	Min	Max
PN20/30	14	8
PN20HT/30/HT	14	8
PN7c	18	10
PN12c/PN12cSS	20	14

*Capacity is based on THHN wire sizes.

NPT	Cable Range
.50"	.062 - 0.50
.75"	.187 - 0.75
1.00"	.437 - 1.10
1.25"	.750 - 1.375
1.50**	.890 - 1.650
2.00**	1.125 - 2.438
2.50**	1.750 - 2.565

* PN12cSS only

General Notes & Precautions

1. This product must be installed by a certified personnel.
2. Do not tin terminal wire ends.
3. Do not use moisture repellent sprays on the contacts.
4. Do not back terminal screws fully out.
5. Do not overtighten accessory screws on nylon/poly angle adapter or handles.
6. ▲ Meltric threaded handles come with tapered style threads. The use of fitting seal tape is recommended to maintain watertightness of all NPT fittings and joints.

ENVIRONMENTAL

Optimum operating conditions are achieved by installing IP66/IP67 plugs and receptacles with the latch at the top.

To prevent water ingress, non-watertight plugs and receptacles must always face downwards when not mated.

Wire Strip Length

Wire strip lengths are indicated in Table 4. Strip lengths for cable sheathing will depend on the specific application. When used with handles, the cable sheathing should extend into the handle to ensure secure cord gripping.



Device/Contact	Receptacle		Plug/Inlet	
	Inches	mm	Inches	mm
PN20/30	3/8	10	3/8	10
PN20HT/30HT	3/8	10	3/8	10
PN7c	5/16	8	5/16	8
PN12c/PN12cSS	3/8	10	3/8	10

Terminal Screw Tightening Torques

The wiring terminals are spring-assisted to prevent loosening due to wire strand settlement, vibration and thermal cycling. Avoid over-tightening. Appropriate tools and tightening torques are indicated in Table 5.

Device/Contact	Torque		Required Screwdriver or Allen Wrench
	in-lbs	N-m	
PN20/30	15	1.7	3 mm or 1/8" precision tip
PN20HT/30HT	15	1.7	3 mm or 1/8" precision tip
PN7c	15	1.7	3 mm or 1/8" precision tip
PN12c/PN12cSS	-	-	solder type terminals

Wiring the Terminal Connections

Verify that power has been disconnected prior to wiring the conductors to the plug and receptacle.

Wiring must be made according to all applicable local and national electrical codes. Check that the rating is correct for the installation. Follow the conductor-coding and terminal markings detailed in Table 6. This product must be electrically grounded. A grounding terminal is provided on all metal accessories, with a green screw and a washer.

For Screw Type Terminals

Insert cable through handle and strip cable jacket to adequate length. The cable jacket should extend at least 1/2" into handle. Back out terminal screws only far enough for conductor to clear. Strip each conductor to 3/8". Twist the strands of each conductor together and insert fully into the terminal. Tighten terminal screws to 15-20 in-lbs.

For Solder Type Terminals

For soldered terminals, use tin solder and a 50 W soldering iron. Insert the conductor into its terminal and heat the terminal for approximately 30 seconds. While heating, apply the soldering wire into the hole at the bottom of the terminal and let it penetrate by capillarity. Let it cool down without any mechanical stress.

Terminal Identification	Function
"G", "E" or GND	Green equipment grounding conductor only (or green with yellow stripe).
"N"	White or gray, system ground (neutral conductor only "N")
PN20/PN30/PN20HT/PN30HT Models	
"1" or "R1" (Black) "2" or "S2" (Red) "3" or "T3" (Blue)	"Hot" conductors, no specific lettered terminal applies to any specific colored conductor
PN7c/PN12c Models	
"1" to "6" or "1" or "11"	"Hot" conductors, no specific lettered terminal applies to any specific colored conductor

ASSEMBLY

Verify that power has been disconnected prior to assembly.

For In-Line Connections

Insert the cable through the handle and gasket. Strip the cable jacket to provide a workable wire length, being mindful that the jacket must extend into the handle to achieve a secure grip. Then strip the wires to the lengths indicated in table 4. When applicable back out the terminal screws far enough (but not completely) to allow the conductors to pass. Insert the conductors fully into their respective terminals and hand tighten to the torques indicated in table 5.

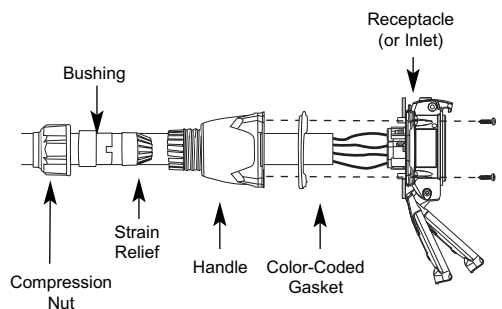

For Mounted Receptacles/Inlets

Insert the cable through the wall box and cut to allow adequate length. Strip the cable jacket to allow a workable wire length. Strip the individual cables to the lengths indicated on table 4. When applicable back out the terminal screws far enough (but not completely) to allow the conductors to pass. Insert the conductors fully into their respective terminals and hand tighten to the torques indicated in table 5. Assemble the receptacle/inlet and the color gasket to the box with the appropriate hardware.

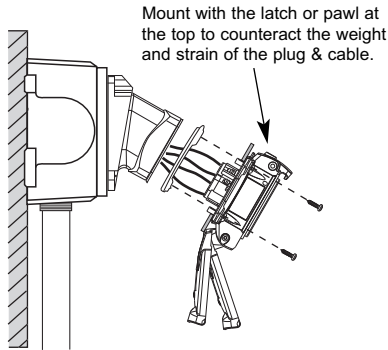

Hole Pattern for Custom Mounting

In applications where custom mounting to a panel or box is desired, the clearance and mounting holes should be drilled as indicated in the following diagram and Table 7.

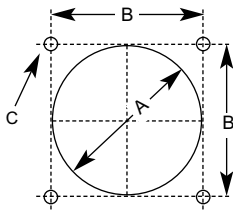

Table 7 - Custom Mounting Dimensions

Model	'A'		'B'		'C'	
	Inches	mm	Inches	mm	Inches	mm
PN20/30	2.00	50	1.65	42	.19	5.0
PN20HT/30HT	2.00	50	1.65	42	.19	5.0
PN7c	2.00	50	1.65	42	.19	5.0
PN12c	2.00	50	1.65	42	.19	5.0
PN12cSS	2.00	50	1.65	42	.19	5.0

OPERATION

To ensure safe and reliable operation, Meltric plugs and receptacles must be used in accordance with their assigned ratings. They can only be used in conjunction with mating receptacles or plugs manufactured by Meltric or another licensed producer of products bearing the **Melrechal**™ technology trademark.

Meltric plugs & receptacles are designed with different keying arrangements, so that only plugs and receptacles with compatible contact configurations and electrical ratings will mate with each other.

Connection

To connect, open the protective plug cap, align the red dots on the plug and receptacle bodies, insert plug into receptacle, apply force and rotate the plug 20° counterclockwise (CCW). The contacts will mate and the circuit will close.

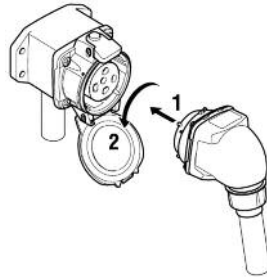

Disconnection

To open the circuit and remove the plug, press the pawl, apply inward force and rotate the plug 20° clockwise (CW). The plug can be safely withdrawn from the receptacle. The plug contacts remain shrouded until after the circuit is disconnected. Close protective plug cap to prevent contamination by dirt, dust or other debris.

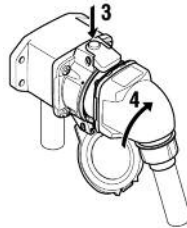

Lockout Provisions

The plug cap can be locked with a locking pawl except PNHT or PN12cSS.

Screw: Plug inserted or cap closed, turn the 5/16" screw with an Allen key until it reaches the bottom. Do not over tighten.

MAINTENANCE

Meltric products require little on-going maintenance. However, it is a good practice to periodically perform the following general inspections:

- Check the mounting screws for tightness.
- Verify that the weight of the cable is supported by the strain relief mechanism and not by the terminal connections.
- Check the IP gaskets for wear and resiliency. In wet/wash-down environments, the gaskets should be inspected periodically (6 months) for wear and hardness. Replace gaskets as needed.
- Verify the electrical continuity of the ground circuit every 6 months.
- Check the contact surfaces for cleanliness and pitting. Deposits of dust or debris can be rubbed off the contacts with a clean cloth. Under no circumstances should the contact surfaces be filed since this will remove the silver-nickel, butt-contact tip degrade contact consistency. Sprays should not be used since they tend to collect dirt.
- If any significant pitting of the contacts or other serious damage is observed, the device should be replaced.

Receptacle contacts may be inspected by qualified personnel. This should only be done with the power disconnected. Any repair or service must be performed with genuine Meltric parts only.

MANUFACTURER'S RESPONSIBILITY

Meltric's responsibility is strictly limited to the repair or replacement of any product that does not conform to the warranty specified in the purchase contract. Meltric shall not be liable for any penalties or consequential damages associated with the loss of production, work, profit or any financial loss incurred by the customer.

Meltric Corporation shall not be held liable when its products are used in conjunction with products not bearing the **Melrechal**™ technology trademark. The use of Meltric products in conjunction with mating devices that are not marked with the **Melrechal**™ technology trademark shall void all warranties on the product.

Meltric Corporation is an ISO 9001 certified company. Its products are designed, manufactured and rated in accordance with applicable UL, CSA and IEC standards. Meltric is also a member of BECMA, the international Butt-contact Electrical Connectors Manufacturers' Association. Like all members, Meltric additionally designs and manufactures its products in accordance with BECMA standards established to ensure intermatibility with similarly rated products manufactured by other members. For more information, visit, www.becma.ch.

